



Pallet Stretch Wrapping Machine

FEATURES

- Adopting programmable control (frequency converter), reliable in performance, convenient in operation; the lapping type and time can be designed on customer's requirements.
- Equipment with a photo electric detector, automatically testing the goods height and controlling the travel limit.
- Rotary table can reset automatically, thus ensuring correction and out position of the tray.



Specification	
Max height	2100mm
Max weight	2100Kg
Roller dimension	1500mm
Roller motor power	0.37KW
Lift motor power	0.18KW
Power	220V 50Hz
Weight	630Kg
Dimension	2620x1620x 650mm

**** Custom -made specification is available and also providing a complete set of packing system of conveying line.**

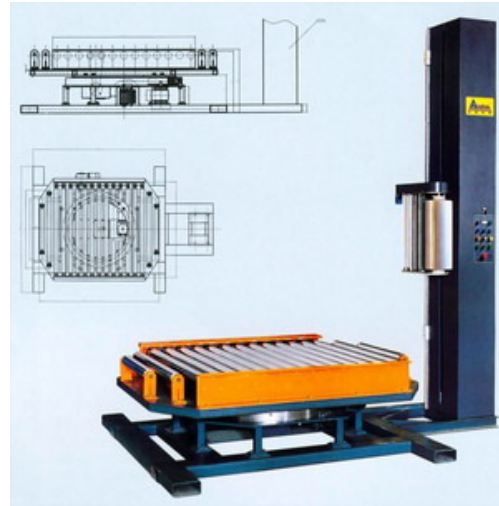

**** Size, height and conveyor system can be custom made according to your wrapping needs. Please contact us for more information.**



RS Series On line Auto Packing System

R-Series On line Auto Packing System is mainly used for high output production capabilities. It can auto detect heavy or light goods, input and output sensing, packing and then conveyor off. You can also chose strap, roller , chain etc. Types of conveyor according to your specifications. The R series can be fully customized according to your needs.

